



EPT20-18WA
EPT20-20WA
EPT25-WA
Electric Pallet Truck 1.8/2.0/2.5t

Long-tiller Design Makes Operations Easier and More Convenient;
Small Turning Radius Requirements, Excellent Performances in Curved Aisles;
Ideal Choice for Heavy Duty but Short Distance Applications.

EP EQUIPMENT CO.,LTD
www.ep-ep.com



▣ FEATURE



Performance

- The innovative AC system offers strong power, accurate control and excellent performance.
- High strength vertical gearbox provides reliable uptime.
- Low-noise and durable hydraulic unit, high quality cylinder as well as hose ensure the high reliability of hydraulic system.
- AMP connector and durable electric wires greatly reduce malfunctions of components.
- One-time formed fork, box type frame and adjustable linkage extends the life of undercarriage.

Safety

- Curved design of front chassis avoids pinching point when lifting.
- Curved design of bottom frame ensures proper ground clearance and avoids hurting operator's feet.
- Emergency reverse belly button protects the operator from getting hurt.
- Emergency disconnecter will cut off power source to avoid accident when the truck goes out of control.
- Anti-rolling back brake keeps the truck from skidding down when truck is out of control or travelling on ramp.
- LBR option avoids cargo from falling down.
- Long operation tiller withstands most impacts from crashes.



Operation

- With the new design of ergonomical tiller head, all buttons can be reached conveniently & comfortably.
- Thanks to the long tiller design, it decreases the steering force greatly which leads to easy operations.
- With its special fork design, it is suitable for all popular pallets.
- Over 180° handle rotation range tiller & compact size ensure small turning radius & excellent maneuverability.
- Creep speed function: when tiller is in near vertical position, the driving speed will decrease automatically, allowing delicate operation in confined space.
- Creep Switch for vertical handle (optional).



Maintenance

- AC traction motor, maintenance free.
- Hour meter and battery indicator remind the operator of battery charging.
- Easily remove the back cover by only losing two bolts; Access to all key components for inspection, maintenance and replacement.
- Easy access for battery maintenance.
- Vertical motor makes the inspection & service much more convenient.
- Control system allows easy trouble-shooting.
- Low voltage lift cut off design protects batteries.



Electric Pallet Truck 1.8/2.0/2.5t EPT20-18WA/EPT20-20WA/EPT25-WA

Distinguishing mark								
1.1	Manufacturer			EP		EP		EP
1.2	Model designation			EPT20-18WA		EPT20-20WA		EPT25-WA
1.3	Drive unit			Electric		Electric		Electric
1.4	Type of operation			pedestrian		pedestrian		pedestrian
1.5	Rated capacity	Q	kg	1800		2000		2500
1.6	Load center distance	c	mm	600		600		600
1.7	Load distance	x	mm	940	916 / 982	937 / 1003	916 / 982	937 / 1003
1.9	Wheelbase	y	mm	1368	1418	1488	1418	1488
Weight								
2.1	Service weight (include battery)		kg	445		535		565
2.2	Axle loading, laden driving side/loading side		kg	745 / 1500		955 / 1580		1070 / 1995
2.3	Axle loading, unladen driving side/loading side		kg	345 / 100		430 / 105		445 / 120
Types,Chassis								
3.1	Tyre type driving wheels/loading wheels					polyurethane/ polyurethane		
3.2	Tyre size, driving wheels (diameter×width)		mm	Φ230x75		Φ230x75		Φ230x75
3.3	Tyre size, loading wheels (diameter×width)		mm	Φ80x60		Φ85x70 / Φ83x115		Φ85x70 / Φ83x115
3.4	Tyre size, caster wheels (diameter×width)		mm	Φ85x48		Φ85x48		Φ85x48
3.5	Wheels, number driving / caster/loading (x=drive wheels)		mm	1 x + 2 / 4		1 x + 2 / 4 / 1 x + 2 / 2		1 x + 2 / 4 / 1 x + 2 / 2
3.6	Track width, front,driving side	b ₁₀	mm	498		498		498
3.7	Track width,rear,loading side	b ₁₁	mm	390 / 450 / 535		370 / 430 / 515		370 / 430 / 515
Dimensions								
4.4	Lift height	h ₃	mm	120		120		120
4.9	Height drawbar in driving position min./max.	h ₁₄	mm	715 / 1200		715 / 1200		715 / 1200
4.15	Lowered height	h ₁₃	mm	85		85		85
4.19	Overall length	l ₁	mm	1735	1748	1818	1748	1818
4.20	Length to face of forks	l ₂	mm	585		598		598
4.21	Overall width	b ₁ / b ₂	mm	710		710		710
4.22	Fork dimensions	s/ e/ l	mm	50 x 150 x 1150	55 x 170 x 1150	55x170x1220	55 x 170 x 1150	55x170x1220
4.25	Distance between fork-arms	b ₅	mm	540 / 600 / 685		540 / 600 / 685		540 / 600 / 685
4.32	Ground clearance, center of wheelbase	m ₂	mm	35		30		30
4.34.1	Aisle width for pallets 1000 × 1200 crossways	Ast	mm	1820		1815		1815
4.34.2	Aisle width for pallets 800 × 1200 lengthways	Ast	mm	2020		2015		2015
4.35	Turning radius	Wa	mm	1560		1595		1595
Performance data								
5.1	Travel speed, laden/ unladen	km/ h	km/h	5.5 / 6.0		5 / 5.5		5 / 5.5
5.2	Lifting speed, laden/ unladen		m/ s	0.051 / 0.060		0.051 / 0.060		0.051 / 0.060
5.3	Lowering speed, laden/ unladen		m/ s	0.032 / 0.039		0.032 / 0.039		0.032 / 0.039
5.8	Max. gradeability, laden/unladen			6 / 16		8 / 16		6 / 16
5.10	Service brake type			Electromagnetic		Electromagnetic		Electromagnetic
Electric-engine								
6.1	Drive motor rating S2 60 min		kW	1.1		1.1		1.1
6.2	Lift motor rating at S3 15%		kW	0.84		0.84		0.84
6.3	The maximum allowed size battery		mm	670 x 180 x 570		680 x 205 x 600		680 x 205 x 600
6.4	Battery voltage/nominal capacity K5		V/Ah	24 / 110		24 / 210		24 / 240
6.5	Battery weight		kg	120		190		220
Addition data								
8.1	Type of drive control			AC		AC		AC
10.5	Steering type			Mechanical		Mechanical		Mechanical
10.7	Sound pressure level at the driver's ear			74		74		74

1.The parameters in the table are of the standard model. For more information, please contact us.
2.The parameters are subject to change without notice.

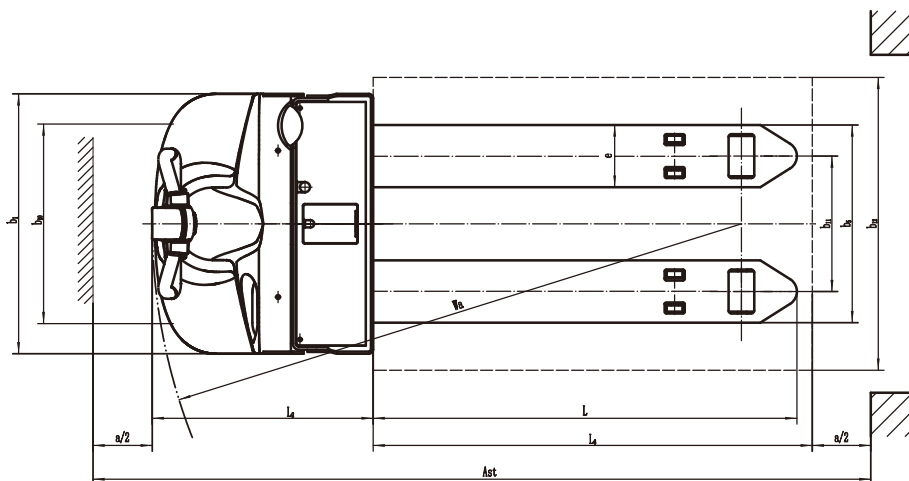
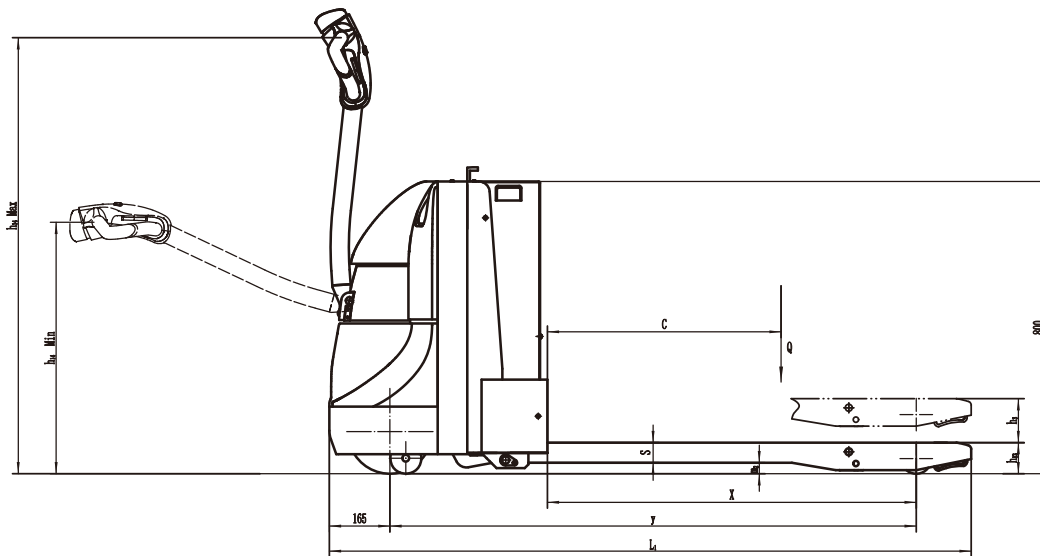

Option

Options	EPT20-18WA	EPT20-20WA	EPT25-WA
Fork length	● 850/1000/1300/1450 mm	● 850/1000/1300/1450/1600/1800/2000/2400mm	● 850/1000/1300/1450/1600/1800/2000/2400mm
Fork spread	—	● 460/790/840mm	● 460/790/840mm
Fork lowered height	● 78mm	—	—
Driving wheel	● PU	● PU	● PU
high capacity battery	● 150AH	● 165AH/240AH	● 165AH/210AH
lateral battery change	—	● 165/210AH/240AH	● 165/210AH/240AH
Cold storage	●	●	●
battery indicator without hour meter	●	●	●
water auto-filling system	●	●	●
Vertical handler working	●	●	●
half speed function in turning	●	●	●
Special backrest	—	● 1220mm (48in)/1520mm (60in)	● 1220mm (48in)/1520mm (60in)